

11. After using, press the power button to turn off the appliance. The unit will shut off automatically after operating for 2 minutes. Press the power button again to continue flossing.

12. After using, follow instructions below to remove the residual water:

- Open the water tank door and empty the water tank.

- Press the power button, the water flosser will automatically drain out residual water.

- Press the power button again to turn off the water flosser; close water tank.

- Wipe the water flosser with a dry cloth.

NOTE: To prevent bacteria buildup, make sure the water flosser is completely drained of water before storing it. Any other servicing should be performed by an authorized service representative or that the product has no user serviceable parts.

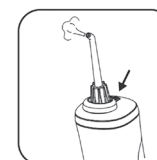
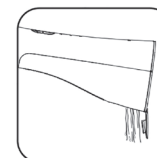

Battery Disposal

Step 1. Remove the 2 screws at the bottom of flosser.

Step 2. Press and hold the tip release button to open top cover.

Step 3. Remove the 2 screws inside the inner cover.

Step 4. Pull out inner cover.

Step 5. Pull out complete bracket.

Step 6. Remove all screws on the bracket.

Step 7. Separate the bracket into two parts by pulling outward.

Step 8. Finally remove battery

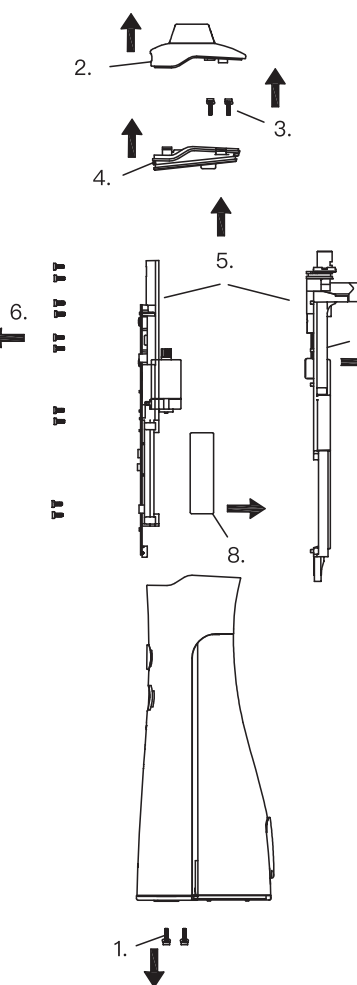

CONTAINS NICKEL METAL HYDRIDE BATTERY. MUST BE COLLECTED, RECYCLED OR DISPOSED OF PROPERLY. DO NOT DISPOSE OF IN THE MUNICIPAL WASTE.

For more information on battery replacement for your power water flosser, call 1-800-334-4031 (8am to 5pm Mountain Standard Time, Mon-Fri).

Every 6 months, completely run down and recharge your power handle to maximize the life of the rechargeable battery.

To help protect the environment, this product is powered by a rechargeable nickel metal hydride battery.

Cleaning and Care of Your Interplak Water Flossing System

Clean the water flosser with clean water or mild detergent, but never use a corrosive or abrasive detergent, as it will damage the water flosser. Do not wash it with water hotter than 122°F (50°C).

1. Clean the body

- Clean the body with a dry or wet cloth.
- Do not immerse the body in water for cleaning.

2. Clean the water tank

- Wipe the water tank with a dry or wet cloth, or detach it and rinse it with water.
- Empty the water tank completely if it is not used for a long time.

3. Clean the water jet tip

- Wipe the water jet tip with a dry or wet cloth, or detach it and rinse it with water.
- Do not bend, pull and twist the water jet tip.
- It is recommended to replace the water jet tip every 6 months

4. Clean the charger

- Wipe the metal part of plug with a dry cloth every 6 months to avoid dust accumulation, which may result in poor contact.

Supplier's Declaration of Conformity

Brand: INTERPLAK by CONAIR

Model No.: WJ15

Description: Rechargeable Portable Water Jet

Responsible Party: Conair Corporation, 1 Cummings Point Road, Stamford, CT 06902 1-800-334-4031

Standards: FCC Part 15 Subpart B, ANSI C63.4-2014

This device complies with Part 15 of the FCC Rules. Operation is subject to the following two conditions: (1) This device may not cause harmful interference, and (2) this device must accept any interference received, including interference that may cause undesired operation.

Date of Issue: 8 April 2020

Troubleshooting Guide

Problem	Possible Cause(s)	Solution(s)
The water flosser doesn't work	The water flosser is being used for the first time or it has not been used for more than 3 months	Charge the water flosser for about 8 hours
Water pressure is low when working	There is something blocking the water jet tip. The water jet tip is deformed	Replace the water jet tip
The water flosser can only be operated for a short time after being fully charged	The water flosser has not charged fully	Charge the water flosser for more than 8 hours before operation
The charging indicator does not illuminate when charging	The power plug has not been connected	Connect to the power source properly
	Circuit malfunction	Contact the service department
Still have questions? Call 1-800-334-4031		

Recommended Tip Replacement Intervals

Replace jet tip every 6 months.

To order replacements parts, call 1-800-334-4031.

Replacement tips available for \$4.99, including shipping and handling.

Replacement tip pack includes 2 jet tips.



Jet Tip

Limited 1 Year Warranty (U.S. and Canada Only)

Conair will repair or replace (at our option) your unit free of charge for 12 months from the date of purchase if the appliance is defective in workmanship or materials. To obtain service under this warranty, return the defective product to the service center listed below, together with your purchase receipt and \$3.00 for postage and handling.

California residents need only provide proof of purchase and should call 1-800-334-4031 for shipping instructions. In the absence of a purchase receipt, the warranty period shall be 12 months from the date of manufacture.

ANY IMPLIED WARRANTIES, OBLIGATIONS, OR LIABILITIES, INCLUDING BUT NOT LIMITED TO THE IMPLIED WARRANTY OF MERCHANTABILITY AND FITNESS FOR A PARTICULAR PURPOSE, SHALL BE LIMITED IN DURATION TO THE 12-MONTH DURATION OF THIS WRITTEN, LIMITED WARRANTY. Some states do not allow limitations on how long an implied warranty lasts, so the above limitation may not apply to you.

IN NO EVENT SHALL CONAIR BE LIABLE FOR ANY SPECIAL, INCIDENTAL, OR CONSEQUENTIAL DAMAGES FOR BREACH OF THIS OR ANY OTHER WARRANTY, EXPRESS OR IMPLIED, WHATSOEVER. Some states do not allow the exclusion or limitation of special, incidental, or consequential damages, so the above limitation may not apply to you.

This warranty gives you specific legal rights, and you may also have other rights, which vary from state to state.

Service Center

Conair Corporation
Service Department
7475 N. Glen Harbor Blvd.
Glendale, AZ 85307

Please register this product at www.conair.com/registration

©2020 Conair Corporation, 7475 N. Glen Harbor Blvd., Glendale, AZ 85307
For more information about Interplak® products, visit www.interplak.com or call 1-800-334-4031

20IN073273

IB-16817

INTERPLAK
by CONAIR

Rechargeable Portable Water Flossing System



Instruction Manual • Model WJ15 (all versions)

For your safety and continued enjoyment of this product, always read the instruction book carefully before using.

Questions or comments? Call 1-800-334-4031

Visit us at our website www.interplak.com

Welcome to Your Rechargeable Portable Water Flossing System

This innovative system from Interplak enhances oral hygiene while significantly contributing to healthy gums when used as part of a responsible oral health management program.

The Interplak Difference

The Interplak Rechargeable Portable Water Flossing System by Conair is designed to help you improve and maintain the highest level of oral hygiene quickly and easily, right at home. This system gently and effectively cleans and flushes food debris from hard-to-reach places – around orthodontic appliances, fixed and removable bridgework, crowns, splints and implants – and provides valuable gum massage with every use.

Interplak Water Flossing System

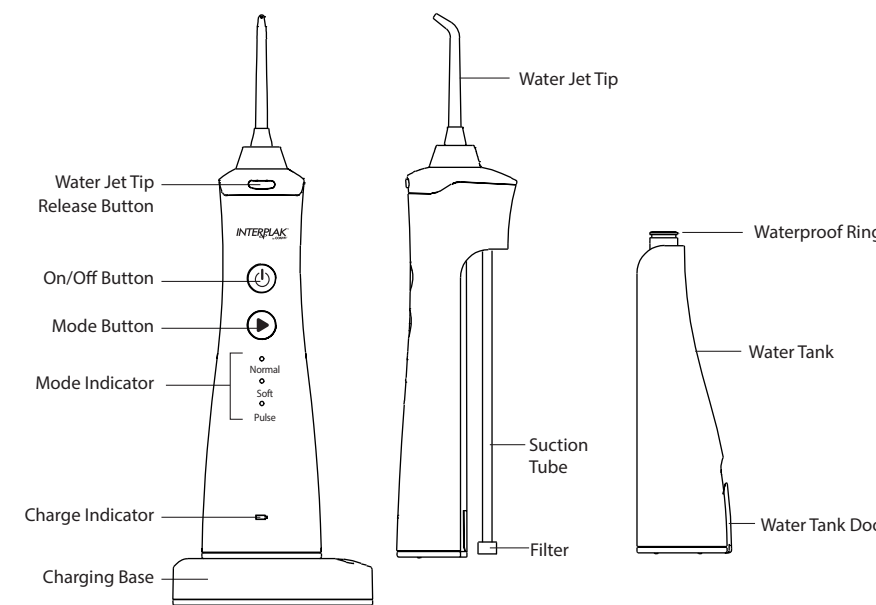

[2]

IMPORTANT SAFEGUARDS

When using electrical products, especially when children are present, basic safety precautions should always be taken, including the following:

READ ALL INSTRUCTIONS BEFORE USING

DANGER – To reduce the risk of electrocution:

1. Do not place or store the unit where it can fall or be pulled into the tub, sink or toilet.
2. Do not place in or drop into water or other liquids.
3. Do not reach into water under any circumstances. Have the unit checked by an Authorized Service Center after it has been immersed in water.

WARNING – To reduce the risk of burns, electrocution, fire, or injury:

1. Do not use while bathing.
2. Do not handle with wet hands.
3. The cable provided fits into a 5VDC USB charger. It is acceptable to use any charger as long as our USB cable fits into the USB port properly.
4. **Never operate the unit if it has a damaged power cord, if it is not working properly, if it has been dropped or damaged or if it has been immersed in liquids. Return the product to a service center for examination and repair.**
5. Do not excessively bend or pull the power cord. Unplug the unit by grasping the plug – not the power cord.
6. Keep the power cord away from heated surfaces.
7. Close supervision is necessary when this product is used by, on, or near children or disabled persons.
8. Use this product only for its intended use as described in this manual or recommended by your dental professional.
9. Do not direct water under the tongue, into the ear, nose or other delicate areas. This product can produce pressures that can damage sensitive areas. See Recommended Technique for correct usage.
10. Unplug this product before filling reservoir. Fill with lukewarm water only unless otherwise specified by your dental professional. Do not overfill.
11. Only use attachments recommended by Interplak.
12. Never use while sleeping or drowsy.
13. Never operate where oxygen or aerosol sprays are being used.
14. For household use only. Do not use outdoors.
15. The unit cannot be operated when cord is plugged in and charging. Wait until the unit is fully charged and unplug cord before use.
16. Do not use concentrated mouthwash in water tank.
17. This appliance is not a toy. Keep away from children.
18. Do not short the polarity (output cord); ensure jack is plugged into the unit before plugging the adapter to outlet.
19. Always attach plug to appliance first, then to outlet. To disconnect, turn all controls to the OFF position before removing plug from outlet. For connec-

[3]

tion to a power supply not in the U.S.A., use an attachment adapter plug of the proper configuration for the power outlet.

Federal Communications Commission Notice

WARNING: Changes or modifications to this unit not expressly approved by the party responsible for compliance could void the user's authority to operate the equipment.

This device complies with Part 15 of the FCC Rules. Operation is subject to the following two conditions: (1) This device may not cause harmful interference, and (2) This device must accept any interference received, including interference that may cause undesired operation.

NOTE: This equipment has been tested and found to comply with the limits for a Class B digital device, pursuant to Part 15 of the FCC Rules. These limits are designed to provide reasonable protection against harmful interference in a residential installation. This equipment generates, uses and can radiate radio frequency energy and, if not installed and used in accordance with the instructions, may cause harmful interference to radio communications. However, there is no guarantee that interference will not occur in a particular installation. If this equipment does cause harmful interference to radio or television reception, which can be determined by turning the equipment off and on, the user is encouraged to try to correct the interference by one or more of the following measures:

- Reorient or relocate the receiving antenna.
- Increase the separation between the equipment and receiver.
- Connect the equipment into an outlet on a circuit different from that to which the receiver is connected.
- Consult the dealer or an experienced radio/TV technician for help.

[4]

SAVE THESE INSTRUCTIONS

MEDICAL WARNING – For your safety:

1. If you have had oral or periodontal surgery in the past 12 months, contact your dentist prior to use.
2. When you start any new oral hygiene program, your gums may initially bleed slightly. Contact your dentist if excessive bleeding occurs or if the slight bleeding continues after two weeks of use.
3. Do not use mouthwashes or rinses that contain iodine, bleach or tea tree oil.
4. Do not use while wearing oral jewelry. Remove prior to use.
5. Do not use if you have an open wound on your tongue or in your mouth.
6. If your physician or cardiologist has advised you to receive antibiotic premedication before a dental procedure, you should consult your dentist before using this oral hygiene aid.
7. Closely instruct and supervise children and individuals with special needs about proper use, and prevent them from playing with this appliance.
8. Be sure that only the water jet tip touches your teeth, gums or tongue. Damage to those areas may occur if any other part of the handle touches them.
9. Use only for oral hygiene cleaning. Do not use for any other purpose.
10. As with any new oral hygiene program, individuals with heart problems should check with their physician prior to using the Interplak Water Flossing System.
11. Connect the power adapter to the socket on the bottom side of the power handle.

WARNING – Changes or modifications to this unit not expressly approved by Interplak will void the warranty. Servicing should always be referred to an authorized service center.

[5]

USER MAINTENANCE

Charging

NOTE: The charging voltage of this appliance is 5V DC. Before charging the appliance, make sure the output voltage of the charger corresponds to the voltage marked on the rating plate of charging base (5V DC). A higher voltage will cause damage to the appliance.

1. If the charging indicator starts to flash when using or after use, the battery is low and needs recharging.
2. Use the provided USB charging base to connect the appliance to a computer USB port or a smart phone charger (ensure the output voltage of the phone charger is 5V DC).
3. Align the round hole at bottom of the handle with the cylindrical pin on the charging base. Place it onto the base to recharge. The charging indicator on the front side of the handle will start to flash.
4. The indicator will stay on when the appliance is fully recharged.
5. It takes 20 hours for the flosser to be fully charged (may vary depending on the environment).
6. Remove the water flosser from the base, then insert the water jet tip into the unit. Adjust the direction of the water jet tip until position feels comfortable for use. Press the water jet tip release button downward to remove the water jet tip.
7. Load the water tank with water either way:
 - Open the water tank door and hold the water jet horizontally. Then fill the water tank with water and securely close the water tank door.
 - Remove the water tank and hold it vertically. Then fill it with water and click the water tank door securely into position.

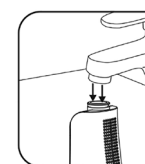
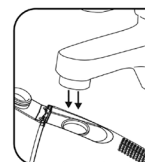
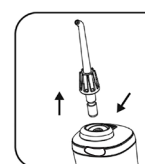
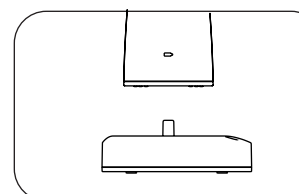
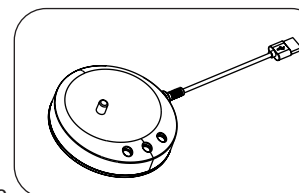

[6]

8. Select your required mode by pressing the Mode button. There are three modes: Normal, Soft and Pulse. Press the Mode button to switch among modes during use.

- **Normal:** For normal cleaning of teeth.
- **Soft:** For sensitive teeth or first-time use, use the Soft mode.
- **Pulse:** For massaging gums to promote blood circulation and strengthen the teeth.

NOTE: For the first week, use the Soft mode until you get used to the water flosser. Once you're comfortable, you can use the other modes.

9. Hold the water flosser vertically and then insert the water jet tip into the mouth and aim at gums or teeth. At the same time, slightly open your mouth to let the water flow out smoothly.

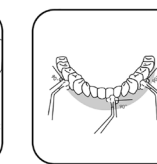

IMPORTANT: Always insert jet tip into the mouth BEFORE activating the water flosser.

10. Press the power button to activate the water flosser.
 - The water will flow out in a direction vertical to gums or teeth.
 - Slowly move the water flosser along the teeth and clean them in order. Do not spray water along the periodontal pocket directly.

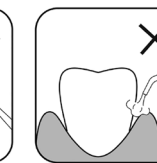
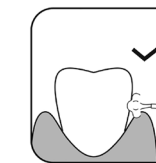

[7]